



Research of AI Driven Light Health and Therapy

Wang Xiaofei^{1*}, Zhao Yi², Ren Jie² and Song Jian³

¹Department of Electronic Engineering Photomedicine Laboratory, Institute of Precision Medicine, Tsinghua University, Beijing, China

²Department of Dermatology, School of Clinical Medicine, Photomedicine Laboratory, Institute of Precision Medicine, Tsinghua University, Beijing Tsinghua Changgung Hospital, Beijing, China

³Department of Electronic Engineering Photomedicine Laboratory, Institute of Precision Medicine, Tsinghua University, Beijing, China

*Corresponding Author

Wang Xiaofei, Department of Electronic Engineering Photomedicine Laboratory, Institute of Precision Medicine, Tsinghua University, Beijing, China, E-mail: wangxiaofei@tsinghua.edu.cn

Citation

Wang Xiaofei, Zhao Yi, Ren Jie, Song Jian (2024) Research of AI Driven Light Health and Therapy. J Artif Intell Syst Appl 3: 1-8

Publication Dates

Received date: September 05, 2024

Accepted date: October 05, 2024

Published date: October 08, 2024

Abstract

This article reports an experimental system of light health and therapy driven by Artificial intelligence (AI) technology. Light health and therapy, also known as phototherapy or bright light therapy, is a therapy used to treat a variety of depression and neurodegenerative diseases, such as Seasonal Affective disorder (SAD) and Alzheimer's Disease (AD). Light therapy affect activity, functional connectivity and plasticity of multiple brain regions by adjusting the frequency and color temperature of illuminating system. The retina converts photon into electrical signals and transmits these stimulus into central nervous system to make resonances and oscillations to boost human mood and improve cognitive function. In life science, non-imaging vision system refers to light signal projected to the higher brain region through ipRGC cell to participate in the regulation of circadian rhythm, emotion, cognition and other functions. The mechanism of this physiological phenomenon is not fully understood. This article induce AI technology to make a closed-loop experimental system to study this phenomenon.

Keywords: Artificial Intelligence; Light Health and Therapy; Signal Processing Algorithm

I. Introduction

Various information from the external environment is transmitted into human brain through different patterns and processed by central nervous system to produce a series of behaviors. Among these modes of perception, light and vision play main contributions to the interaction between the external environment and the human. About 70 percent of human perceptual information comes from light, far more than hearing, touch, and other sensory systems. The visual system is a part of the central nervous system that is used for visual perception, processing, and interpreting visual information to establish a representation of environment. With the development of science and technology, academic community has a certain understanding of the optical vision system, but the complexity makes the function and principle of the visual system still shrouded in mist.

The exploration of light health and therapy in life sciences has made great progress in the last decade. The 2017 Nobel Prize in Physiology and Medicine has been awarded to Jeffrey Hall, Michael Rosbash and Michael Young. They found that in highly light sensitive organisms, the biological clock is a functional system jointly formed by photosensitive neurons, endocrine system, and the regulation of gene timing oscillation expression, which enables organisms to form a circadian rhythm from the micro level of gene expression and cell metabolism to the macro level of biological behavior [1]. This research led neuroscientists to focus on the effects of visible light on living organisms, and marked the beginning of light health and therapy research. Li-Huei Tsai et al., from MIT, re-

ported that Noninvasive 40 Hz light stimulation promotes 40 Hz neural activity in multiple brain regions and regions attenuates pathology in mouse models of Alzheimer's disease [2]. Boyden and Li-Huei Tsai established The MIT team established Cognito Therapeutics to push light therapy on neurodegenerative diseases to the clinical trial stage [3]. While light therapy has made clinical breakthroughs, the principle of the therapy is unclear yet. As a result, light therapy varies from person to person. The physiological signals of different patients require special testing, adjustment, and analysis to determine the effective frequency of different patients. The method generates a large number of human electrophysiological signals data, and manual analysis is insufficient. This article describes a suite of AI driven light health and therapy system to address this problem. In section 2, design and functions of the system are introduced. Section 3 shows the deployment, testing and data of clinical trials. The preliminary result is discussed in section 4, and finally the future development and improvement of the system and algorithm are prospected in section 5.

II. System Design and Functions

A. System Design

As shown in Figure 1, the light health and light therapy system described in this paper consists of three subsystem units: light stimulation unit with adjustable frequency, a human factor engineering data acquisition unit (human electrophysiological signal data acquisition unit), and a data processing AI algorithm unit. The functions of each subsystem unit are described below.

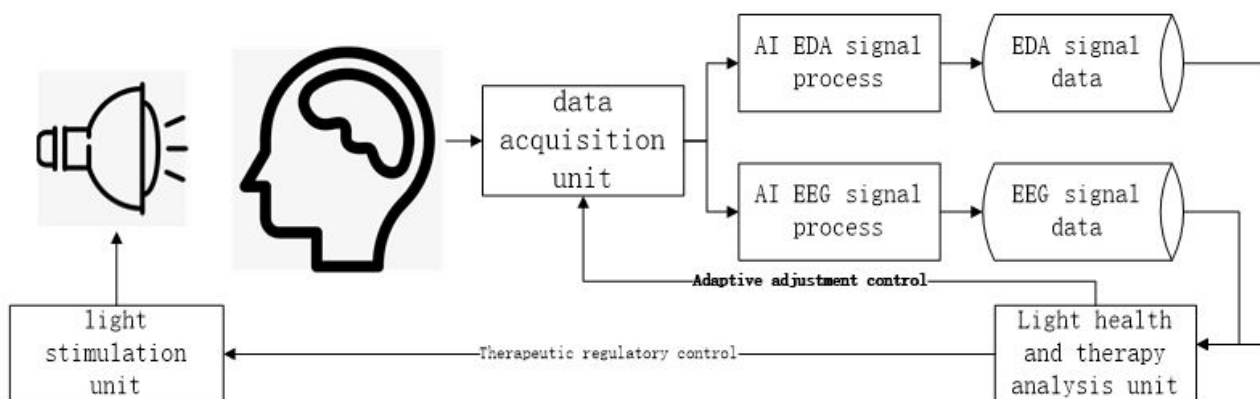

Figure 1: Light health and light therapy system design

B. Light Stimulation Unit

The function of light stimulation unit is to control the light flicking frequency, color temperature, and brightness so that

the person in the environment can obtain the best light health and therapy state. As shown in Figures 2 and 3, light affects the human visual and nervous system through different physiological channels.

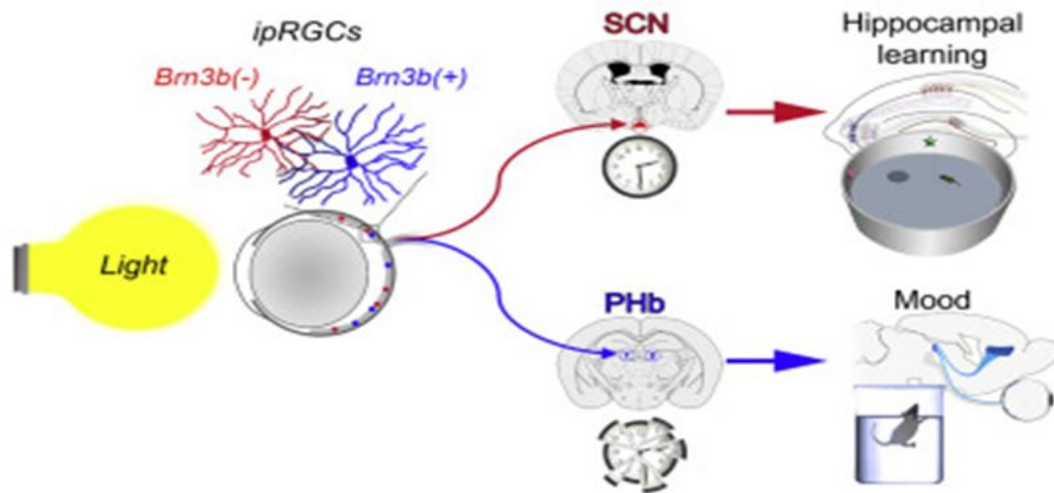

Figure 2: Light as a central modulator of circadian rhythms, sleep and affect [4]

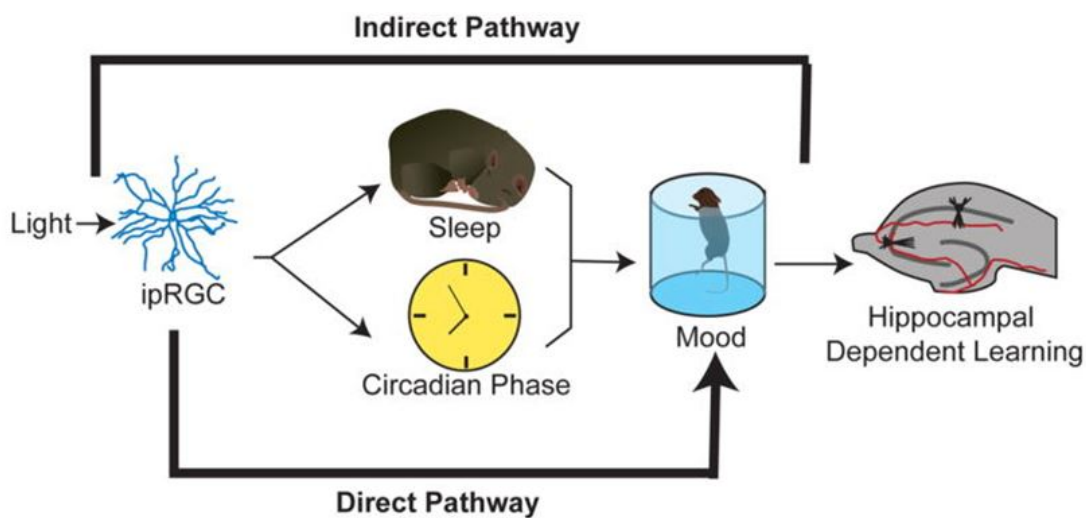

Figure 3: Light affects mood and learning through distinct retina-brain pathways

C. Data Acquisition Unit

The data acquisition unit uses the equipment shown in Figure 4 to collect EEG (Electro Encephalo Gram), ECG (Electro Cardio Gram) and EDA (Electro Dermal Activity) signal from volunteers in clinical medical experiments. Figure 4 also shows the deployment of stimulation, acquisition, and observation in a real experiment. The experiment was a non-invasive volunteer experiment with ethical approval from Ts-

inghua University's Changgeng Hospital.

D. AI Algorithm Unit

AI algorithm unit is a set of flexible and customized algorithm pipeline based on AI technology to process EEG, ECG and EDA signal sets collected in the experiment. The main function is to filter the signal containing noise, counting, statics and find the specific waveform within physiological significance. The data form, process and results will be discussed in

sections 3 and 4.

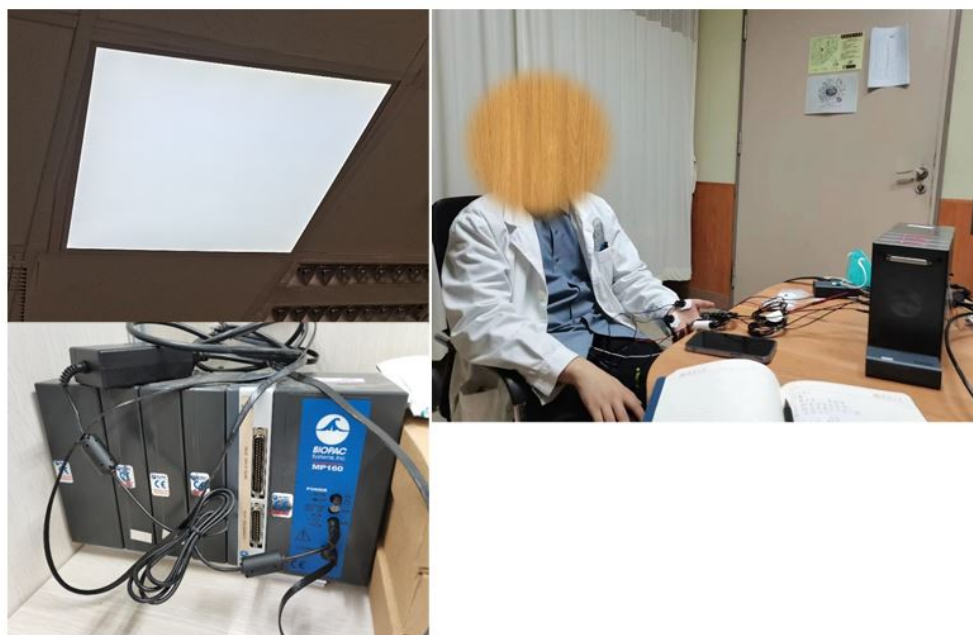

Figure 4: Experimental deployment at Tsinghua University's Changgeng Hospital

III. Deployment, Testing and Data of Clinical Trials

A. Clinical Trials Setup

The LED dimming system was used as the stimulus output unit in the experiment. The size was 600mm×600mm, and the rated voltage and power were 42W, as shown in figure 4. The LED light flashing frequency, light intensity and color temperature parameters are controlled with wireless and real-time. The physiological data acquisition system uses a multi-channel data acquisition device based on BIOPAC MP160 [5] and multiple data acquisition modules to collect various physiological data (EEG, ECG and EDA) in real time. The data is recorded synchronically for easy analysis in the future. Data collection is reliable and stable. The experiment was certified as ethical and safe by the hospital. The volunteers had no adverse reactions.

B. Testing and Data

Each volunteer was stimulated for 10 minutes with 6 sets of flashing frequency light at 0,40,80,160,250 and 500Hz. Take a 10-minute break between each stimulus. It is generally considered that 40 and 80Hz are visible stroboscopic sensations of the human body, and the other frequencies are invisible, but

there may be other physiological response. This system uses objective physiological electrical signals to study the response of volunteers under different strobe stimuli. Each volunteer was collected two hours of EEG, ECG and EDA signals as shown in figure5.

IV. Preliminary Result

A. Preprocessing

In the data preprocessing stage, different frequency filter are deployed. Users can select from filter library construct data preprocessing pipeline. Figure 6 shows the filtering effect of one of the Butterworth filters (cutoff frequency set to 0.2Hz, order 3).

B.EDA

In the system described in this paper, a series of AI algorithm of EDA signal is implemented. The basic characteristic model of EDA signal is shown in Figure 7.

In this paper, AI algorithm is used to analyze the basic model of skin electrical signals for important signal features. The main concerns are amplitude, quantity, and delay time, rise time, recovery time, etc. The electro dermal response localization algorithm in AI EDA algorithm realizes a comprehensive

localization strategy based on maximum, difference and base- line. The time domain EDA signal before and after processing by AI algorithm is shown in Figure 8.

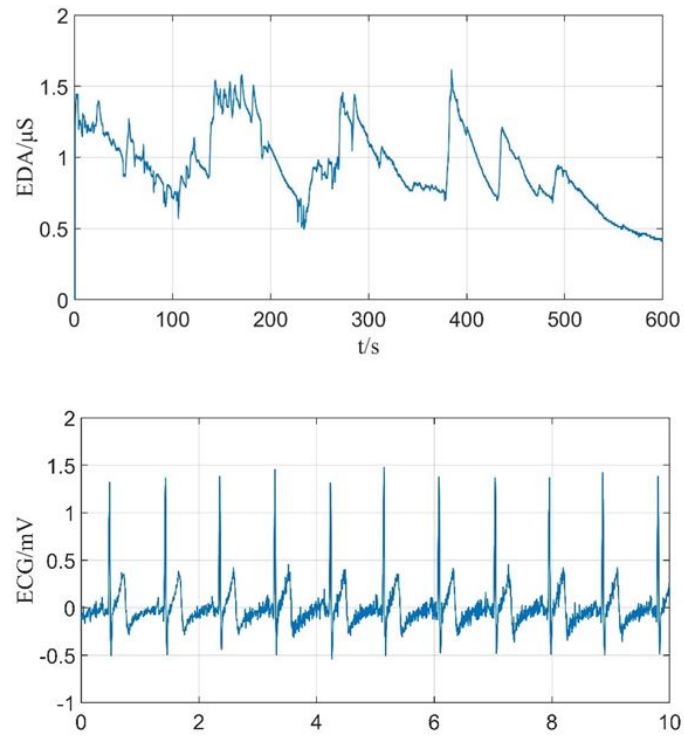

Figure 5: Raw data of ECG and EDA signal collected from volunteer

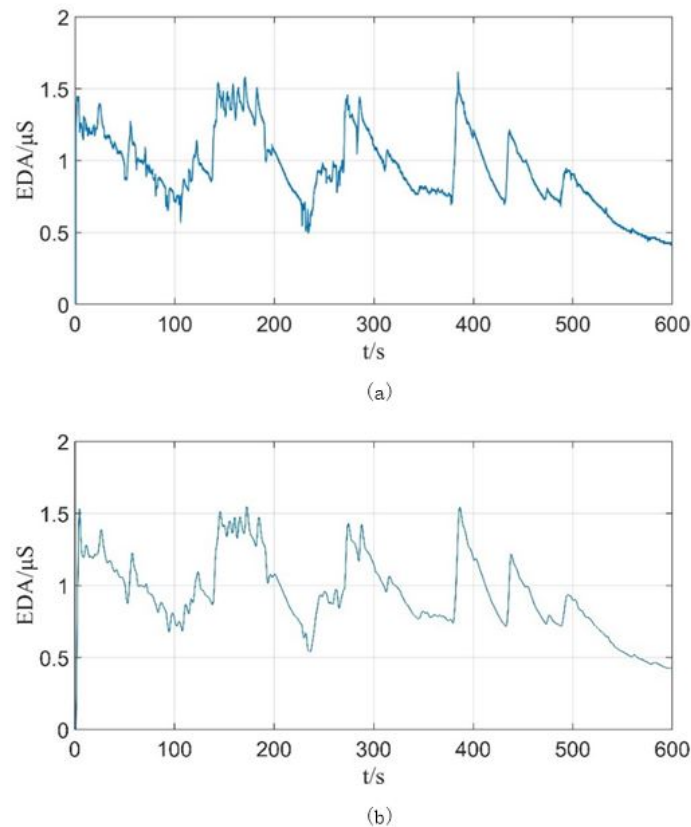

Figure 6: Butterworth filters (a) before data preprocessing; (b) after data preprocessing

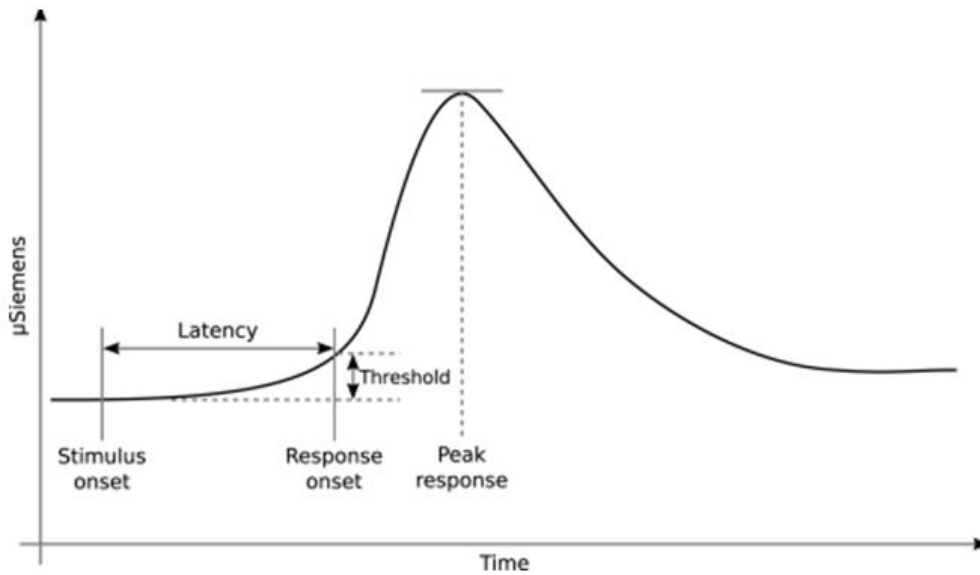
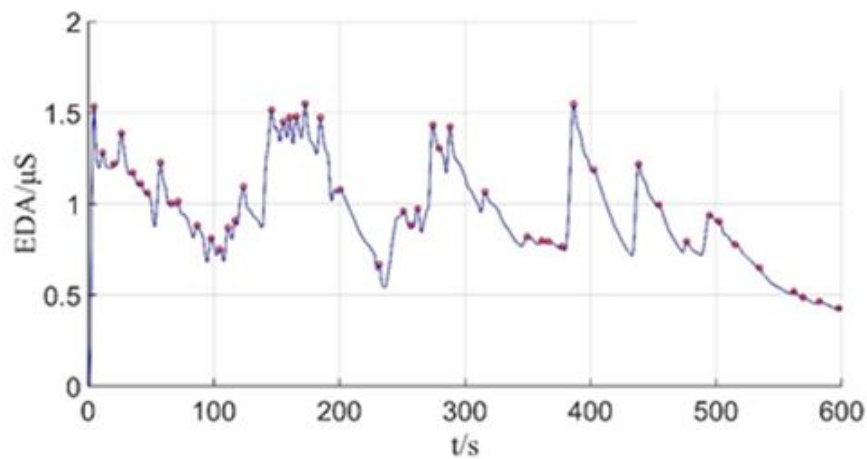
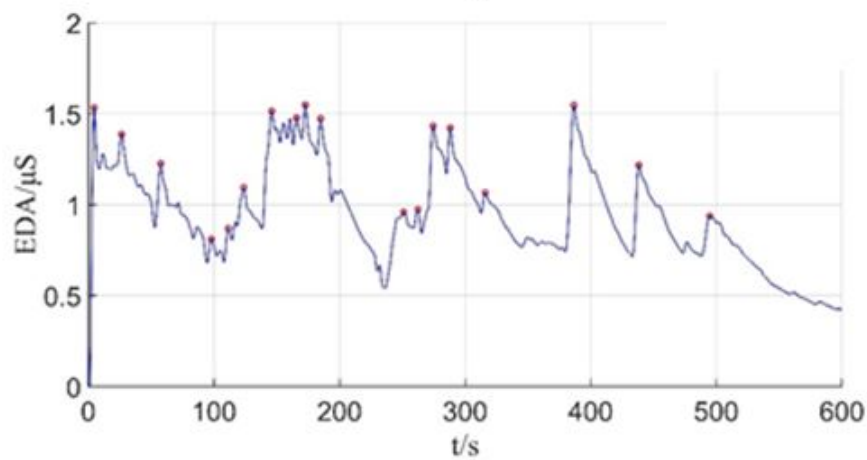

Figure 7: skin conductance response with characters [6]



(a)



(b)

Figure 8: AI EDA algorithm with localization strategy (a) before data preprocessing; (b) after data preprocessing

C.EEG

In the system described in this paper, AI algorithm is used to implement the segmentation and recognition of basic EEG signals. The EEG signals shown in Figure 9 can be extracted

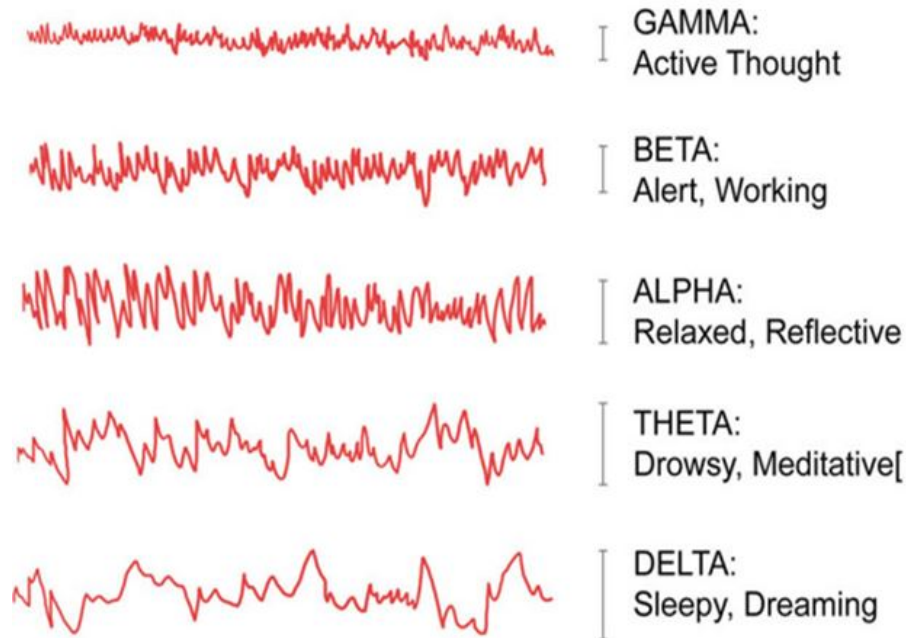

Figure 9: Brain wave in different frequency: Tune the brain wave with LED, might control the state of the brain

V.Future Work

This paper described an experimental system of light health and therapy driven by Artificial intelligence (AI) technology. The design, implementation and preliminary clinical trial of the system proved that the system is a close loop of light health and therapy and is effective. The analysis of data between stationary state and stimulated state by AI algorithm shows that there is a large individual difference in baseline data, and the adaptive adjustment function of AI algorithm is necessary. By analyzing the effect of stroboscopic stimulation, it is proved that the effect of stroboscopic stimulation on electro cutaneous data is obvious. The paired T test was performed between the experimental group and the control group to test the significance of the difference. The results showed that compared with 0Hz, 40,80,160Hz strobe stimulation significantly increased the amplitude of electro dermal response

by basic clustering algorithm. Different types of brain waves correspond to different neural states of volunteers, and their biological and medical significance needs to be further analyzed.

with statistical significance. The 250Hz strobe stimulation also increased the electro dermal data ($p=0.0541$). 500Hz has almost no effect.

This result may change the conventional understanding that strobe light has no effect on humans above 80Hz. Future studies are expected to further demonstrate the rationale for non-visual light health and therapy.

Acknowledgment

The work was sponsored by Tsinghua-Toyota Joint Research Fund (From 2022/11 to 2024/11). The work was supported by Photomedicine Laboratory, Institute of Precision Medicine, Tsinghua University (No. 100010706). The work was supported by Sunrise Medical Technology Co.,Ltd, ChengDu, and we would like to express our sincere gratitude to Mr. Sun Yizheng, President of the company, for his support.

References

1. Nobel prize website, (2017) [Online]. Available: <https://www.nobelprize.org/prizes/medicine/2017/press-release/>
2. Murdock MH, Yang CY, Sun N et al. (2024) Multisensory gamma stimulation promotes glymphatic clearance of amyloid. *Nature*.
3. Cognito Therapeutics, <https://www.cognitotx.com/>.
4. LeGates TA, Fernandez DC, Hattar S (2014) Light as a central modulator of circadian rhythms, sleep and affect. *Nat Rev Neurosci*. 15: 443-54.
5. Biopac System Inc. Data Acquisition & Analysis: Ethernet & USB Solutions MP160 Starter Systems. <https://www.biopac.com/product-category/research/systems/mp150-starter-systems/>
6. Combe E, Fujii N (2011) Depth perception and defensive system activation in a 3-d environment. *Front Psychol*. 2: 205.